

## BUILDING DEMOLITION – POSITIVE ASPECT OF PROGRESSIVE COLLAPSE

*MARIN LUPOAE*<sup>1</sup>

*CARMEN BUCUR*<sup>2</sup>

**Abstract:** *Progressive collapse is a failure mode of great concern for tall buildings, and is also typical for building demolition. Engineers are nowadays more and more interested in structures integrity estimation and collapse theory finding, in order to develop strategies for increasing or decreasing the progressive failure. A new method has been developed, for the last years, called Applied Element Method, which has a large practicability for failure modelling. This paper has two main goals: (i) a short presentation of the Applied Element Method and (ii) the presentation of a case study both as mathematical modelling and as demolition of structure.*

**Keywords:** *Progressive Collapse, Demolition, Explosion, Modelling, Simulation, Applied Element Method.*

### 1. Introduction

Extreme loading produced by explosion on a building can be seen at least from two points of view: (i) as a necessity to demolish a structure and then it occurs the condition to perform this task in a safe and economical manner; (ii) as a local failure produced by terrorist attacks and then it is desirable that the building endure a certain level of damage without this initial damage lead to collapse of the structure.

The progressive collapse term is used to describe the spread of a local failure like a chain reaction, which lead to the partial or total collapse of the building. The main feature of progressive collapse is that the total damage is disproportionate to the original cause.

Based on such descriptions it was proposed by specialists the following definition, ASCE 7-05 [1]: *progressive collapse* - the spread of an initial local failure from element to element, eventually resulting in the collapse of an entire structure or a disproportionately large part of it.

---

<sup>1</sup> Military Technical Academy, Department: Integrated Systems of Armament - 81-83 George Cosbuc Ave., Sector 5, 050141, Bucharest, Romania, e-mail: [mlupoae@mta.ro](mailto:mlupoae@mta.ro)

<sup>2</sup> Technical University of Civil Engineering, Department: Mechanics of Structures – 124 Lacul Tei Ave, Sector 2, 020396, Bucharest, Romania, e-mail: [bucur\\_ig@utcb.ro](mailto:bucur_ig@utcb.ro)

There is a difference between this definition and controlled building demolition because in such type of works there are destroyed many or all the columns on a floor and repeated all or a portion of the process on many floors [2]. Although this is not “local failure,” the process used to design a project is an instructive one, and can lead to a better understanding of how a structural engineer can design to mitigate progressive collapse. This is the reason why is better to begin the complex study of progressive collapse with a building demolition case in order to see what are the ways to approach such type of phenomenon.

Some authors consider that the interest in progressive collapse survey was impelled by three events: gas explosion occurred in an apartment on the 18th floor of a 23-story precast concrete building at Ronan Point – London in 1968, the explosion of a truck bomb in front of the Alfred P. Murrah federal building in Oklahoma City, in 1995 and the terrorist attack against World Trade Center towers, on September 11, 2001.

## **2. Same theoretical aspects regarding “Applied Element Method”**

In the last period occurred the necessity of studies concerning the response of structures subjected to earthquakes, blast-effects, unexpected impact forces and fire, that are known as extreme loading conditions. In addition to these, the controlled demolition of structures is more and more an actual concern. These types of loading conditions are followed by discontinuities in the structural system, so that parts of it became discrete elements. The finite element method - the most used one for structural analysis of continuum mediums - cannot be applied for this stage of the structural system.

Beginning 1996, professors Hatem TAGEL-DIN (Institute of Industrial Science, The University of Tokyo, Tokyo, Japan) and Kimiro MEGURO (International Center for Disaster-Mitigation Engineering - INCEDE), have developed a new method for structure modeling. This is the “Applied Element Method” and combines features from finite element and discrete element methods. The main advantage of this method is that it can track the structural collapse behavior passing through all stages of the application of loads, elastic stage, crack initiation and propagation in tension-weak materials, reinforcement yielding, element separation, element collision (contact), and collision with the ground and with adjacent structures. The time needed for a complete analysis is acceptable and the accuracy of the results is satisfactory. In literature there are many articles regarding this issue.

There are presented in the following some basic theoretical aspects regarding the applied element method.

The structure is modeled as an assembly of small elements, with special shape and determined dimensions. These types of elements do not deform, the

change of their position is as a rigid medium. AEM elements are connected using the elements entire surface, through a series of connecting springs that adopt all material type and properties [3, 4, 5].

There is a single type of element. There are used cuboids to model the structure to be analyzed, fig. 1.

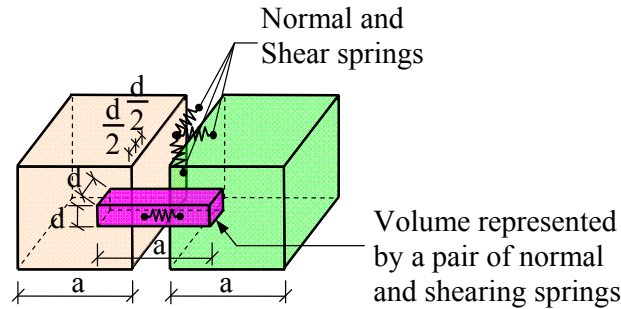

**Figure 1.** Applied element

Two elements are connected through a series of contact points. In every point are attached three springs: a normal spring and two shear springs. Each group of springs completely represents stresses and deformations of a certain volume and each element has six degree of freedom, fig. 2.

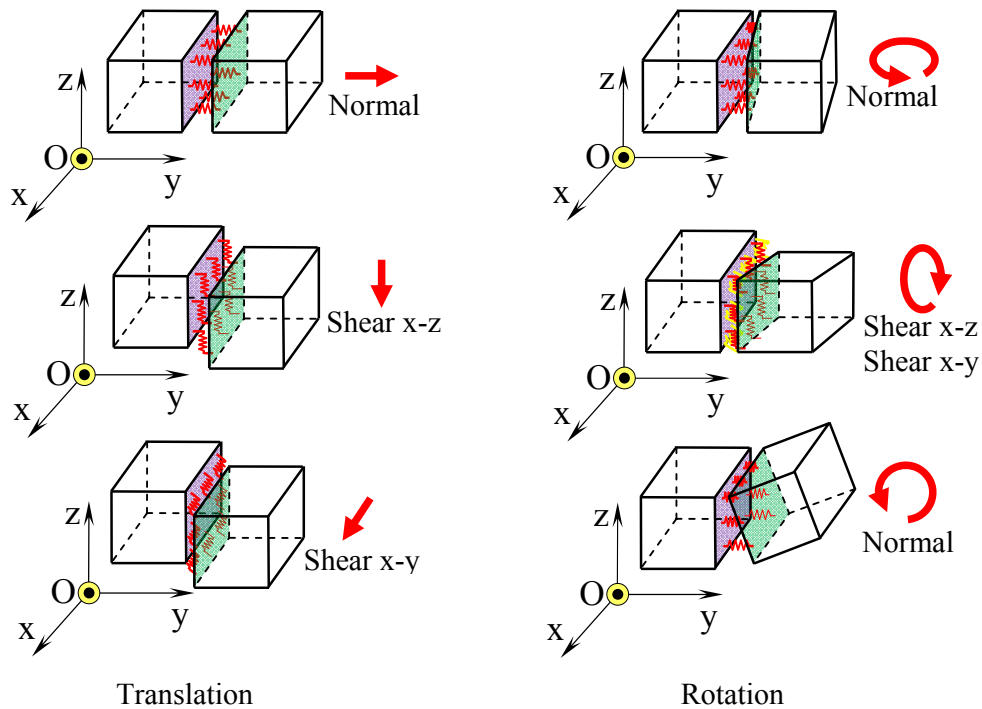

**Figure 2.** The attached springs

Referring to Eq.(1), the spring stiffness is determined as [3]:

$$K_n = \frac{E \cdot d \cdot T}{a} \text{ and } K_s = \frac{G \cdot d \cdot T}{a} \tag{1}$$

where,  $d$  is the distance between springs,  $T$  is the thickness of the element and  $a$  is the length of the representative area,  $E$  and  $G$  are the Young's and shear modulus of the material, respectively. The above equation indicates that each spring represents the stiffness of an area ( $d \cdot T$ ) with length  $a$  of the studied material. In case of reinforcement, this area is replaced by that of the reinforcement bar. The equation (1) indicates that the spring stiffness is calculated as if the spring connects the element centerlines.

There is no need for transition elements, it is allowed the partial element connectivity and the springs are generated at interface of elements, fig. 3.

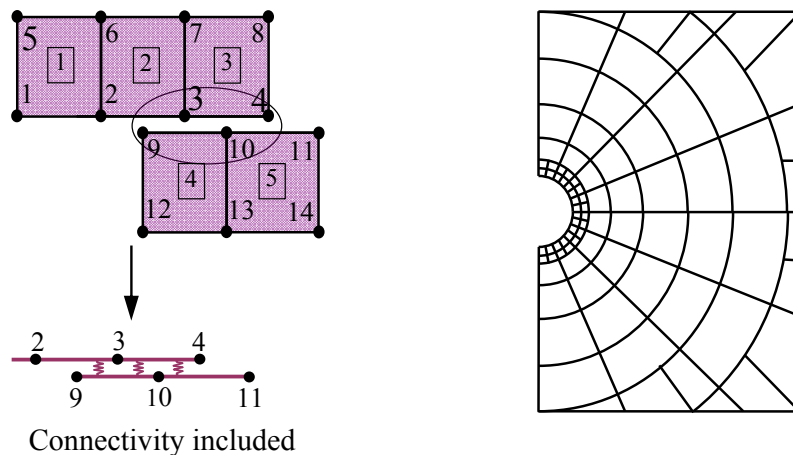

**Figure 3.** Connectivity

The global stiffness matrix  $[K_G]$ , is determined as sum of contributions of all springs used for modeling the structure:

$$[K_G][\Delta] = [F] \quad (2)$$

where,  $[K_G]$  is the global stiffness matrix;  $[\Delta]$  the displacement vector and  $[F]$  the applied load vector. In load control case, the vector,  $[F]$ , is known before the analysis. In displacement control case, the load is applied by unit virtual displacement for one or more degrees of freedom.

The using of this modeling method allowed that the initiation and propagation of cracks and the failure of the structure can be studied using only one initial model. The main advantage of the method is that it can follow the structural behavior since the application of load, crack initiation and propagation, separation of structural elements and till total collapse in reasonable time with reliable accuracy.

### 3. Practical and numerical realization of a building demolition – case study

There are many causes that can lead to progressive collapse of a structure [6]. More often than not this phenomenon is unwanted and more and more

specialists are interested in study of it. The most of studies have a purpose of performing buildings less sensitive to progressive collapse. There is a special case and this is the controlled demolition using explosives of buildings. In this case is needed the identification of that structural elements of building and then the removal of them in a precise sequence, by successive explosions, at time intervals very well established, so that to lead to the progressive collapse of structure in wanted conditions. All these tasks have to be performed using small explosive amount in order to reduce unwanted effects (aerial shock waves, fragments propulsion and seismic type waves) at minimum [7].

### 3.1 Structure description

The structure for demolition was a reinforced concrete building with load-bearing walls and columns. The building had a rectangular shape with 17.50m and 7.60m plan dimensions and height of 33.40m, fig. 4. It had a bay of 5.95 m and five side spans between 2.35 and 4.25 m. The building was placed close to another building with a gap between them of 0.05 m. Facades were made by reinforced concrete walls and glass windows. The roof was made by reinforced concrete slabs fitted with thermal and water insulation. Stairs and the elevator were placed at south-west part of building.

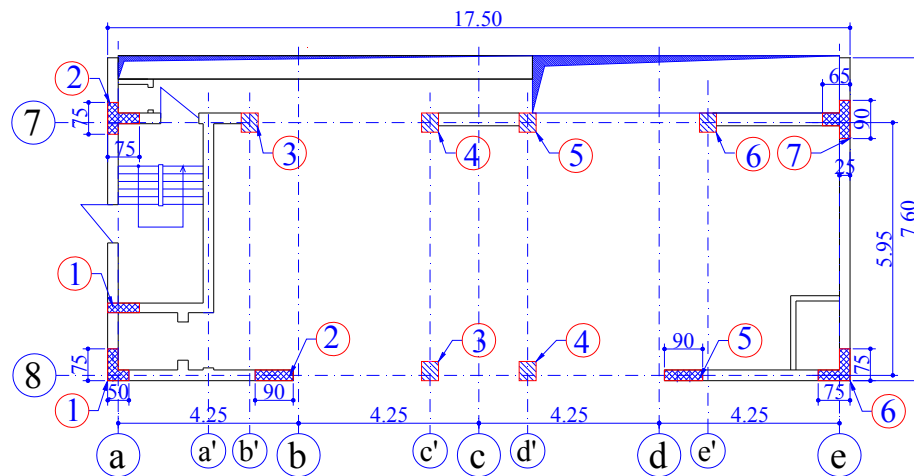

**Figure 4.** Plan of first floor of the building (the digits in circle represent the explosion steps).

The structure consisted in reinforced concrete columns and walls stiffened through slabs. The reinforced concrete columns, with dimensions of cross section of 0.45x0.40 m, were centrally placed, whereas walls, with thickness of 0.25 m, were placed on contour. There were floors consisted in slabs with thickness of 0.15 m and a network of beams with dimensions of 0.25x0.55 m, respectively 0.25x1.00 m.

### 3.2 Practical realization of demolition

Preparation of building for demolition consists in uncoupling of

construction from power, water and gases utilities and preparatory mechanical works. The first step in preparation is to clear any debris out of the building. Next, construction crews begin taking out non-load-bearing walls within the building. These steps are needed in order to minimize the consumption of explosive and thus to decrease aerial shock waves and fragments propulsion effects. Also, the clearing out of the bearing or nonbearing walls in this stage, is needed in order to create the necessary space to accelerate the dropping of structure in the collapse initiation zone.

Grouping of explosives charges, in explosions steps, was established taking into account the collapse trajectory and the limitation of explosive amount per explosive step, as you can see in fig. 5. It can be seen that steps consist in one or more support elements in order to get the collapse trajectory and the acceleration of structure after collapse initiation. The time intervals among explosion steps were milliseconds range (0.025 s or more) and they were imposed by features of blasting caps used to set off the explosive charges placed into blast holes.

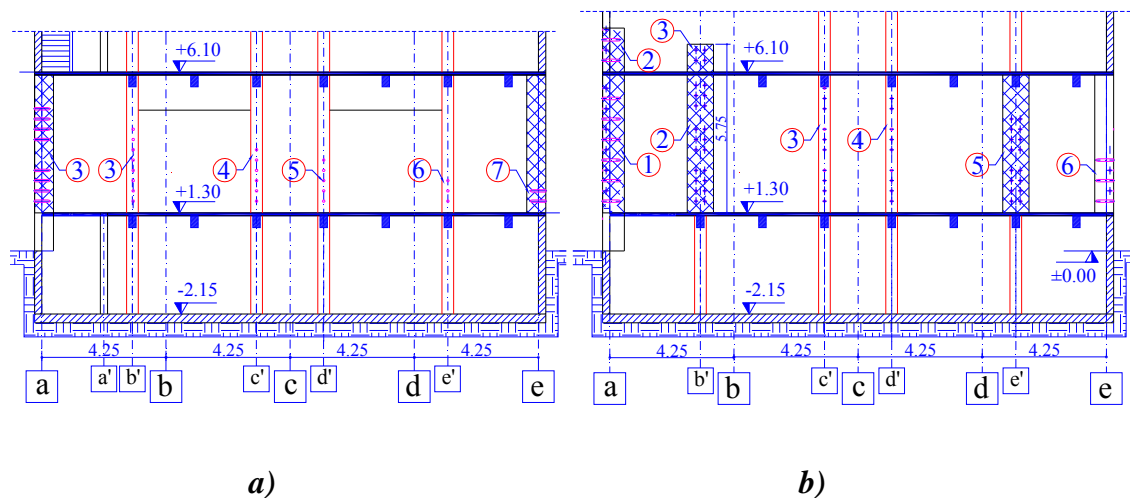

**Figure 5.** Explosions steps: a) for axis 7 and b) for axis 8

### 3.3 Numerical Evaluation

The numerical evaluation of controlled demolition using explosives was performed using Extreme Loadings of Structures (ELS) software [8]. This software use Applied Element Method (AEM) to simulate progressive collapse of structures.

In order to simulate the demolition of building it was necessary to follow these steps:

- (a) The geometrical modeling of building, fig. 6;
- (b) A demolition scenario. This step consists in structural elements specification, sequence and time intervals among explosion steps. The sequence of elements destruction is presented in fig. 5. In this stage is indicated, also, the

time of analysis and time step. For this analysis were used two values for time step: a time step of 0.001 s used in order to see the behavior of structure between two steps of explosion and a step of 0.01 s used to verify the collapse trajectory and the level of structure damage;

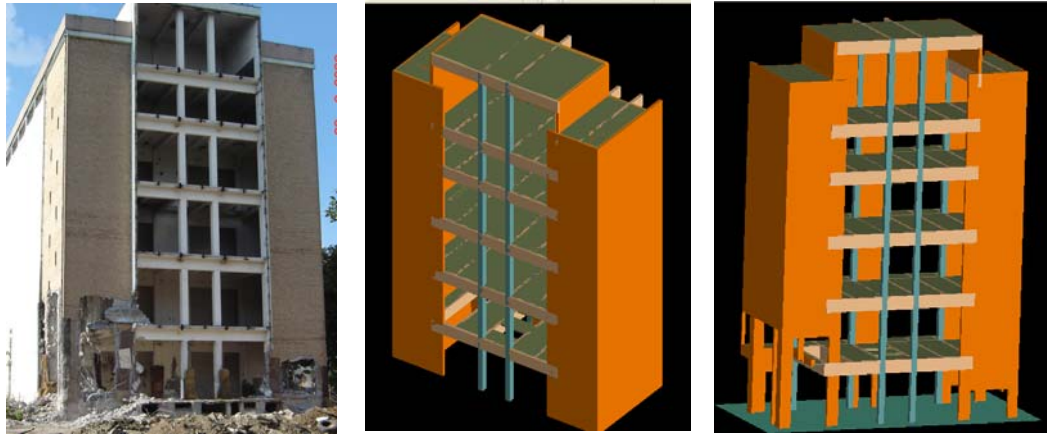

a)

b)

c)

**Figure 6.** Real and simulated structure before demolition:  
a) real construction after preparatory works; b) geometrical model of structure; c) geometrical model of structure before starting simulation.

(c) The integrity of structure verification and running analysis. For a time step of 0.001 s, with a Pentium (M) processor 2.0 GHz, it take more than 110 hours to reach 0.2 s for phenomenon, that can take more than 3 s;

(d) The verification and interpretation of results. In this stage were followed two aspects: (i) the mode of stress redistribution; (ii) the collapse trajectory and final level of damage.

In order to see the way of loads redistribution there were chosen some points, indicated in fig. 7, and corresponding to these points there were determined displacements, fig. 8, and vertical forces, fig. 9.

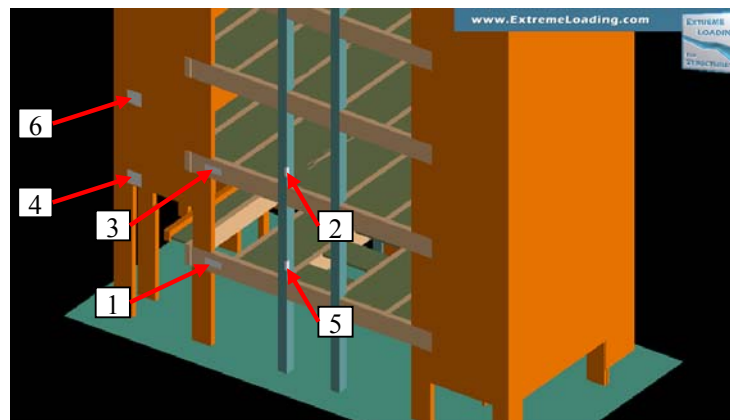

**Figure 7.** Points where were determined displacements and vertical forces

## 4. Results

After the curves of displacements were analyzed it can be made the following commentaries: **(i)** points where occur accentuated changing in downgrade correspond to moment of explosions (0.025 s, 0.050 s, 0.075 s, 0.100 s, 0.150 s, 0.200 s and 0.400 s) and thus to the moment of support elements destruction; **(ii)** the irregular form of displacement curve corresponding to first story longitudinal beam shows the exact moment when the support elements were demolished; **(iii)** curves corresponding to points 4 and 6 are almost identical because there are placed on a system like wall, that will be move on vertical direction without destruction until it hits the ground.



**Figure 8.** Displacements corresponding to points indicated in fig. 7

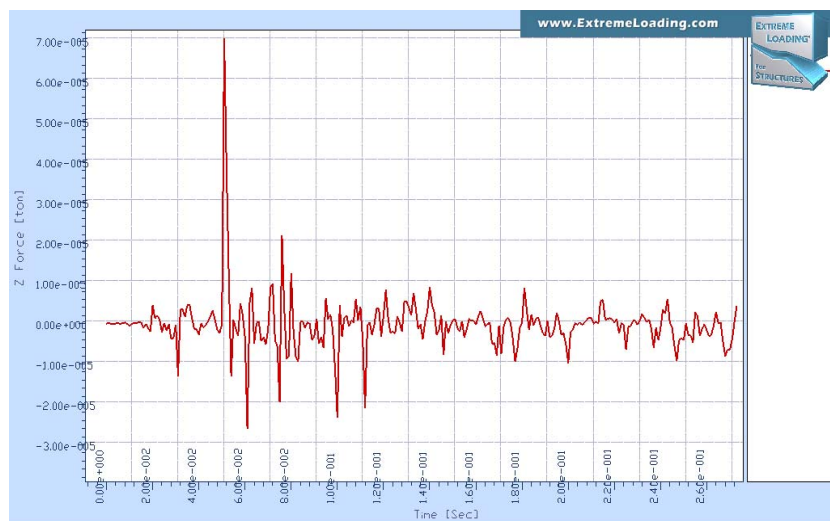
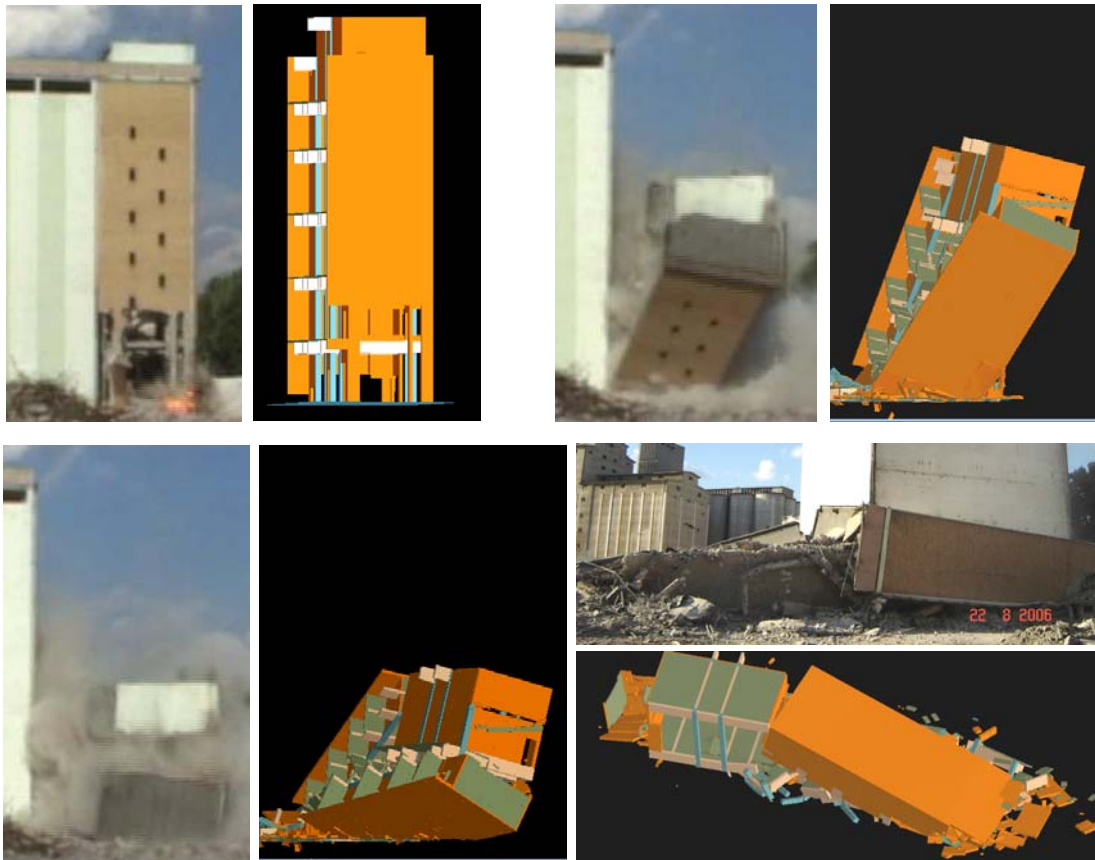

**Figure 9.** Variation of vertical force corresponding to point 1, fig. 7

To better understand how the structure responded to the column removal and to study the propagation of deformation over the height of the structure, the variation of axial forces in the columns above the removed column was examined.

Analytical results showed that following an instantaneous removal of the first story column, for axes  $\delta$  and  $b'$ , at time  $t=0.075$  s, a sudden unbalanced force at joint in the second floor was formed, fig 9. This unbalanced force resulted in a high acceleration of joint and as a result, it started to move downwards and the second story column elongated, which in turn lead to the reduction of the axial compressive force in this column.

In terms of collapse trajectory and level of damage of structure, after it hits the ground, the results of simulation are comparable with that obtained in the properly demolition, as it can be seen in fig. 10.



*Figure 10. Implosion and numerical simulation of the building demolition*

## 5. Conclusion

1. „Applied Element Method” combines features of Finite Element Method and Discrete Element Method, having as main advantage the possibility to describe the behavior of structure beginning with loadings application,

initiation and propagation of cracks, elements separation until total collapse of the structure.

2. In order to see the way of loads redistribution there were chosen some points and corresponding to these points there were determined displacements and vertical forces. It can be seen that points where occur accentuated changing in downgrade correspond to moment of explosions and thus to the moment of support elements destruction.

3. It is shown that the joints above one of the removed columns, in two different floors, moved almost identically with the floor above having slightly smaller displacement.

4. The results show a good correlation between numerical simulation and real demolition of the structure.

**Acknowledgement:** The authors acknowledge the support of the PN II-CNCSIS-IDEI, ID\_8/2007.

## References

1. ASCE Standard ASCE/SEI 7-05, *Minimum Design Loads for Buildings and Other Structures*, American Society of Civil Engineers, Reston, Virginia, 2005.
2. LOIZEAUX, M., OSBORN, A.E.N. – *Progressive Collapse – An Implosion Contractor’s Stock in Trade*, Journal of Performance of Constructed Facilities, vol. 20, No 4, 2006, pp. 391-402
3. MEGURO, K., TAGEL-DIN, H., (2001) – *Applied Element Simulation of RC Structures under Cyclic loading*, Journal of Structural Engineering, vol. 127, No 11, 2001, pp. 1295-1305
4. MEGURO K., TAGEL-DIN H. S. - *Applied Element Method Used for Large Displacement Structural Analysis*, - Journal of Natural Disaster Science, vol. 24, No 1, 2002, pp 25-34
5. TAGEL-DIN H., RAHMAN N. A. - *The Applied Element Method: The Ultimate Analysis of Progressive Collapse*, Structure Magazine, No 4, April 2006, pp 30-33.
6. LUPOAE, M., BUCUR, C. – *Explosion - Accidental, Controlled or with Malice Purpose – Cause of Progressive Collapse*, The 8<sup>th</sup> International Scientific Conference SIMEC - UTCB, Bucharest, Romania, 27 march 2009, pp. 131-138 (in Romanian)
7. LUPOAE, M. – *Considerations regarding the using of explosive energy for controlled demolition of buildings*, PhD thesis, Military Technical Academy, Bucharest, Romania, 2004, (in Romanian)
8. \*\*\* - *Extreme Loading for Structures - Technical Manual*, ASI, 2006